



The Majorana Neutrinoless Double-beta Decay Experiment

Reyco Henning

U. of North Carolina -- Chapel Hill



Neutrinoless Double Beta-decay

T4.00003 : Henry Primakoff Lecture: Neutrinoless Double-Beta Decay, J. Wilkerson



- Immediate Implications of Discovery:
 - Neutrino is Majorana (own antiparticle)
 - Total Lepton Number is not conserved
 - Neutrino has mass (known)
- Well-studied example: Exchange of virtual neutrino.
- Could probe absolute Mass-scale of Neutrino:

$${}^Z A \Rightarrow {}^{Z+2} A + 2e^{-}$$

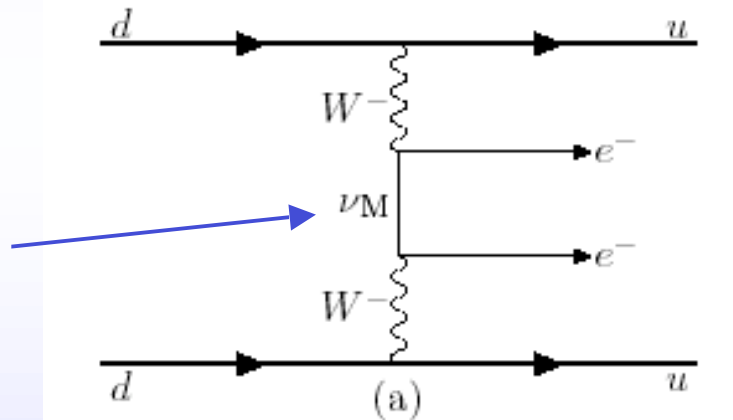

$$\left[T_{1/2}^{0\nu} \right]^{-1} = (\text{Matrix Element}) \times (\text{Phase Space}) \times \langle m_{\nu} \rangle$$



Experimental Considerations



- Measure *extremely* rare decay rates :
 $T_{1/2} \sim 10^{26} - 10^{27}$ years ($\sim 10^{13}$ x age of universe!)
- Large, highly efficient source mass.
- Extremely low (near-zero) backgrounds in the $0\nu\beta\beta$ peak region-of-interest (ROI) (1 count/t-y)

1. High Q value
2. Best possible energy resolution
 - Minimize $0\nu\beta\beta$ peak ROI to maximize S/B
 - Separate $2\nu\beta\beta/0\nu\beta\beta$

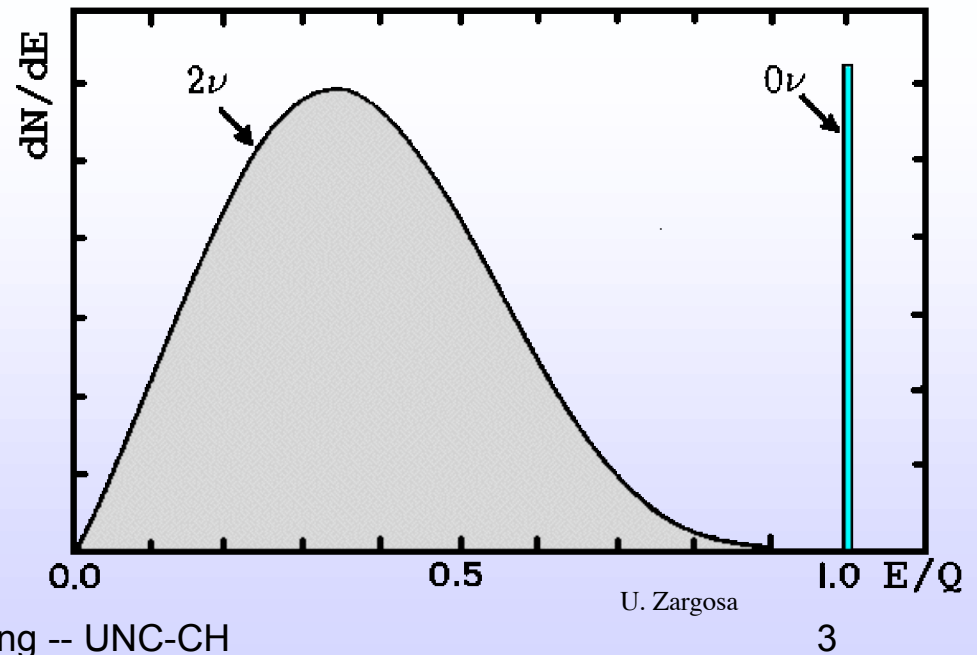



Ge Detection Principle



- Majorana uses ^{76}Ge
- Enriched HPGe Diodes -- Detector is Source.
- Excess at $Q = 2039 \text{ keV}$
- Demonstrated in IGEX, Heidelberg Moscow.
- Intrinsically clean

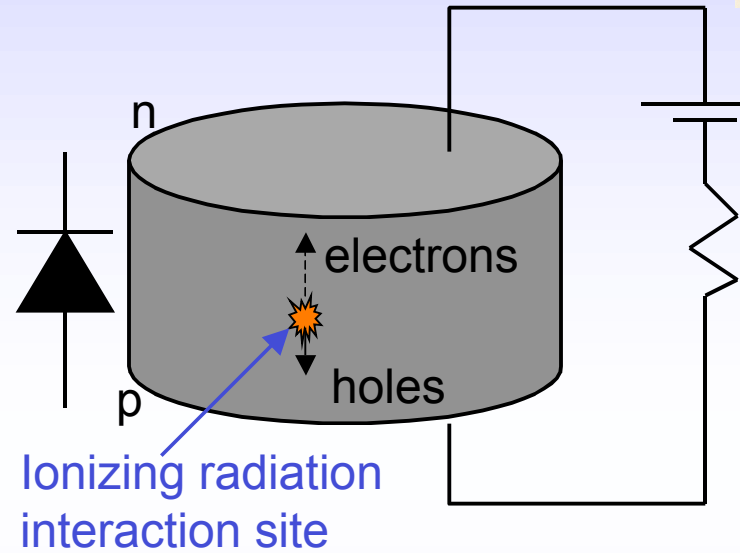

- ➡ **HPGe Detectors have excellent energy resolution**
- ➡ **0.16% at ROI for Majorana**



Majorana R&D

Towards a 1-tonne experiment



- Phase I: Construct 30-60 kg R&D Module
- Mixed detectors, enrichment levels
- Goals:
 - Selection of optimal detector design:
 - Highly/modestly segmented
 - Modified electrode
 - Unsegmented p-type
 - Verification of background simulation.
 - Materials, in particular cable and copper shielding.
- Continued cooperation with GERDA collaboration (MaGe, materials, Lar Shield)



The Majorana Modular Approach



1 Concept: 57 crystal modules

Conventional vacuum cryostat made with electroformed Cu.

Scalable to 1-tonne

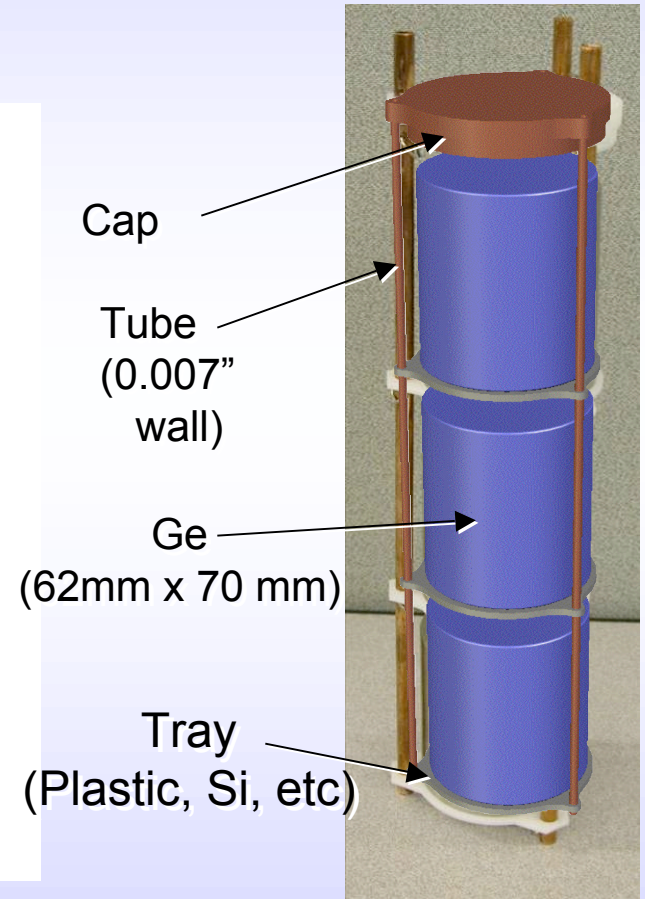
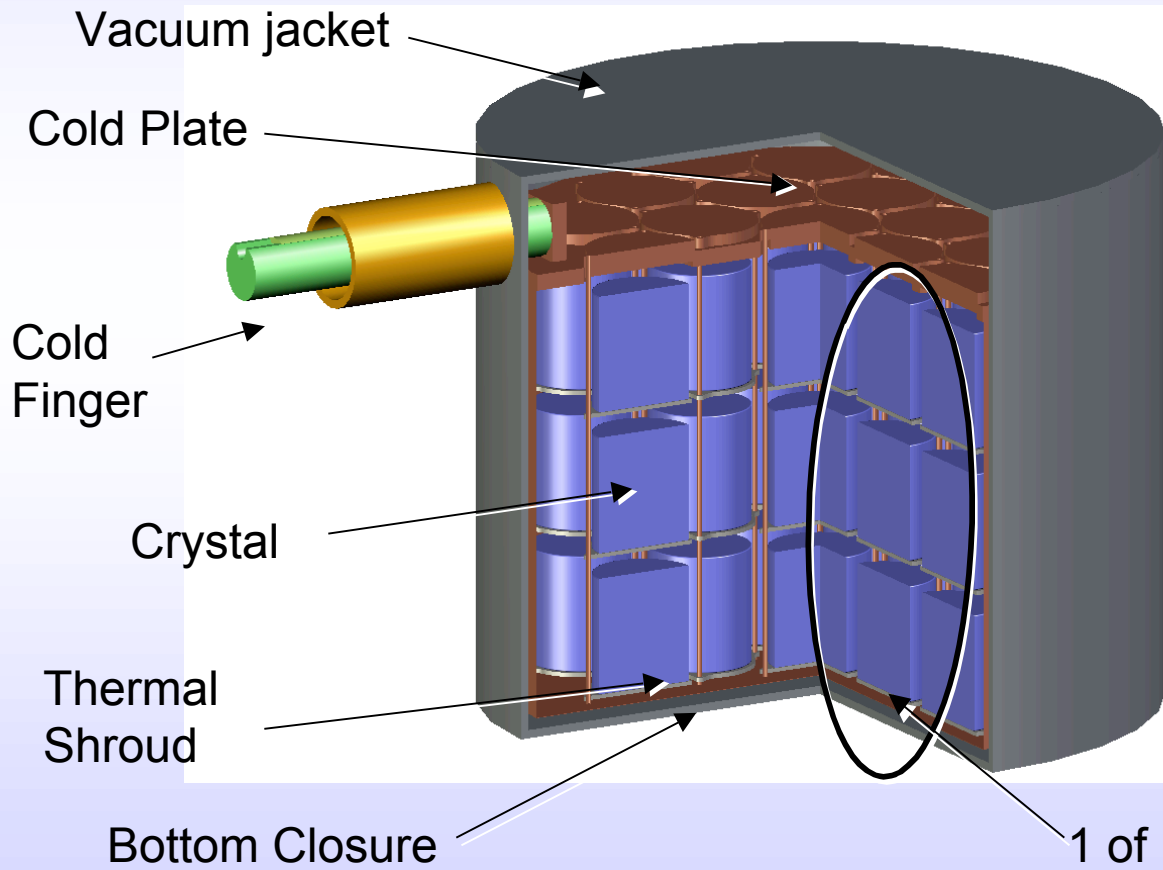



Background Identification



- Majorana is background limited.
- Goal: 1 event / ton-year in 4 keV ROI
- Backgrounds:
 - Natural isotope chains: ^{232}Th , ^{235}U , ^{238}U , Rn
 - Cosmic Rays:
 - Activation at surface creates ^{68}Ge , ^{60}Co .
 - Hard neutrons from cosmic rays in rock and shield.
 - $2\nu\beta\beta$ -decays.
- Need factor ~ 100 reduction over what has been demonstrated.
- Monte Carlo estimates of acceptable levels
- **Most backgrounds are multi-site. Signal is single-site**



Materials and Shielding



- Ultra-radiopure materials
- Deep underground: >5000'
- Modular deployment.
- 40 cm bulk Pb, 10 cm ultra-low background shield
- Active 4π veto detector

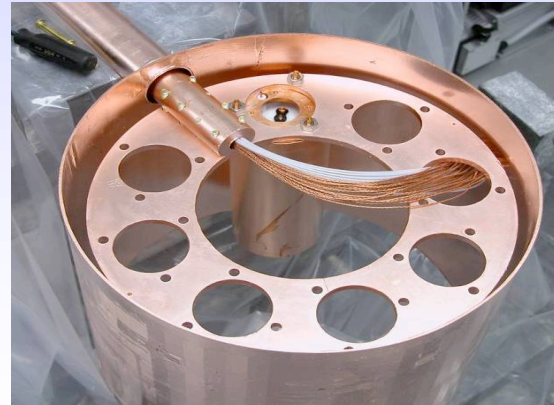

Top view

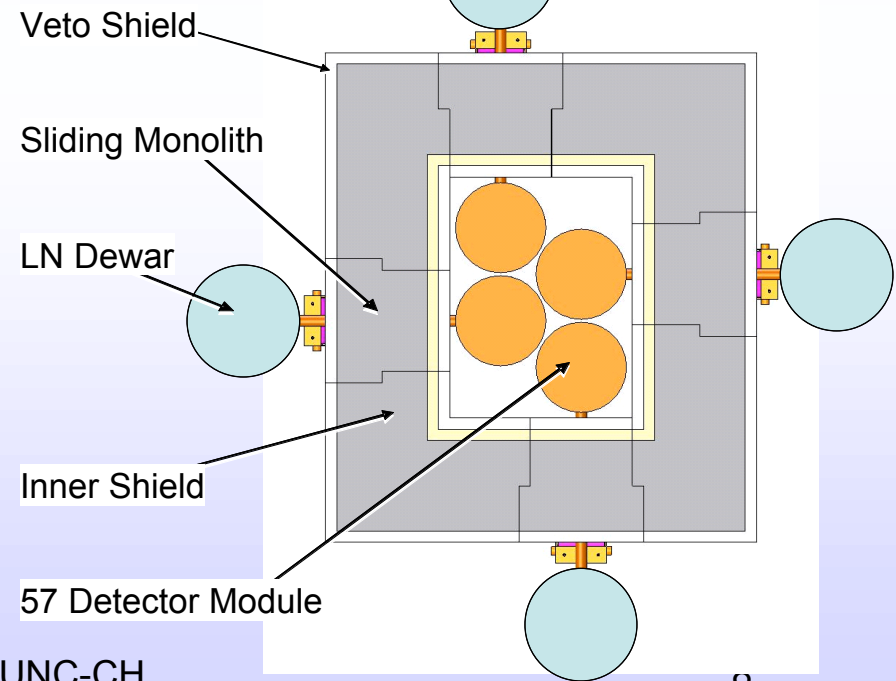
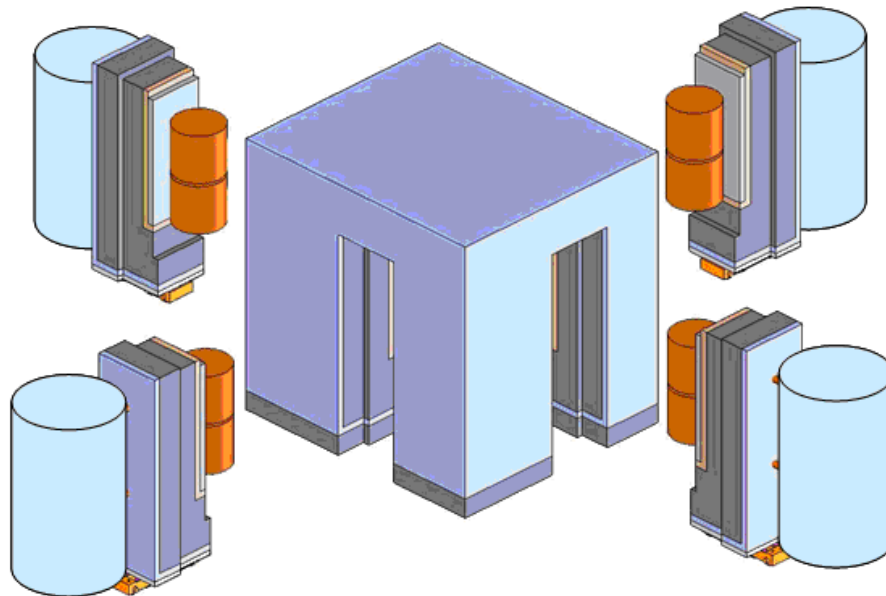

4/16/07

R. Henning -- UNC-CH



Pulse-shape discrimination

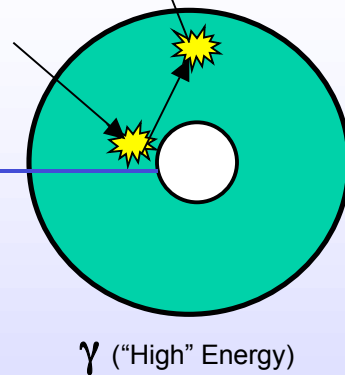
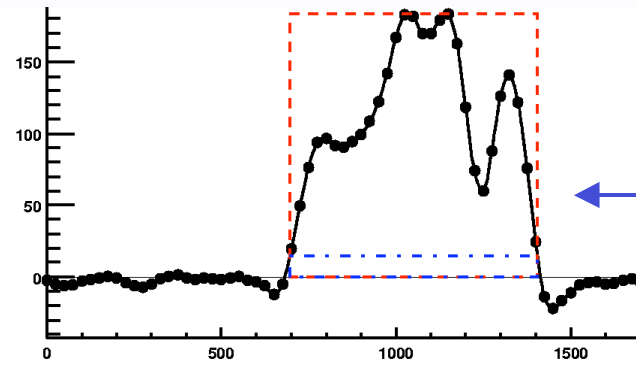
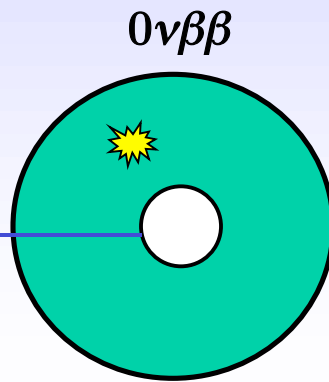
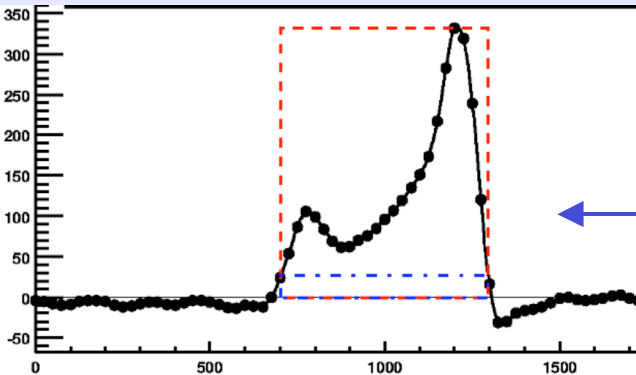

Segmentation

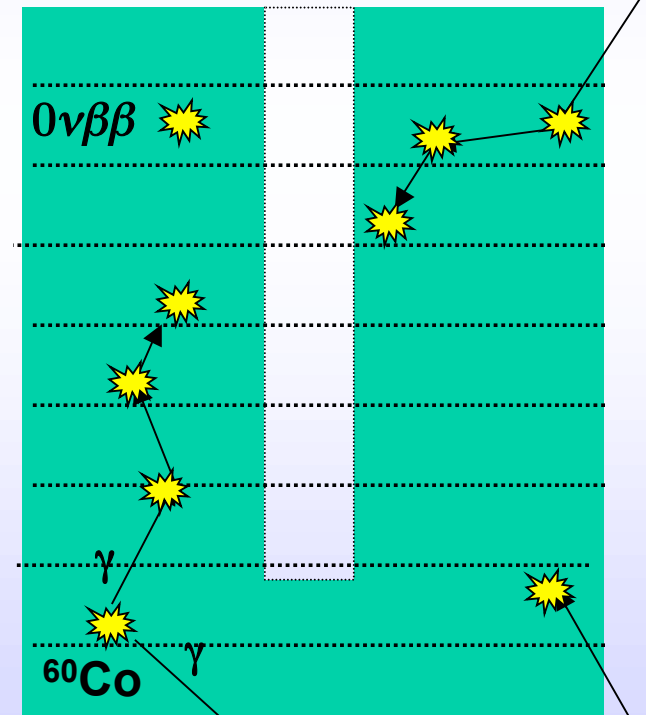
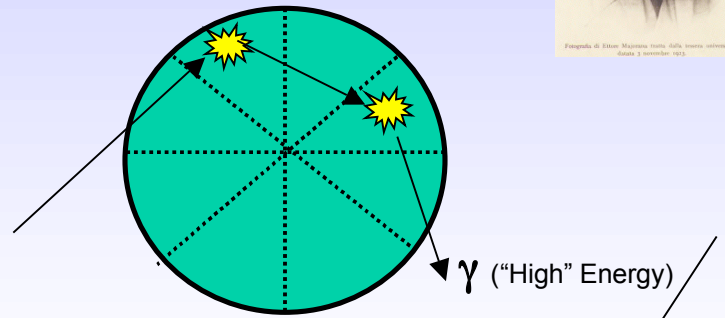

4/16/07

R. Henning -- UNC-CH

γ ('Low' Energy)
9



Majorana Simulation



Simulated Geometry
Shields & Cryostat Removed

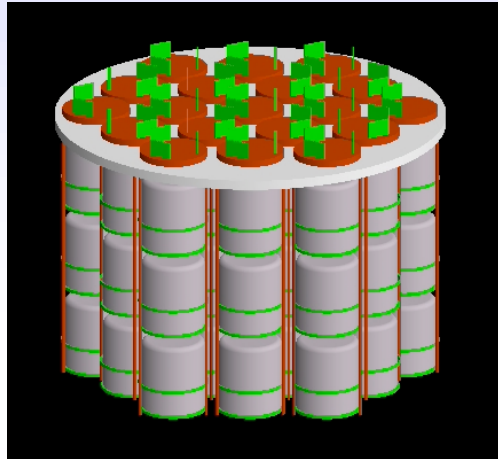

Simulation Includes:

- 57 Enriched crystal w/ deadlayers.
- LFEPs
- Support Rods
- Ge Trays
- Contact Rings
- Cryostat
- Surface Alphas
- Shields:
 - Inner, Outer Cu
 - Inner, Outer Pb
 - Neutron shield.
 - Room, rock wall.
- 45,000 CPU hours, 12,000 jobs.

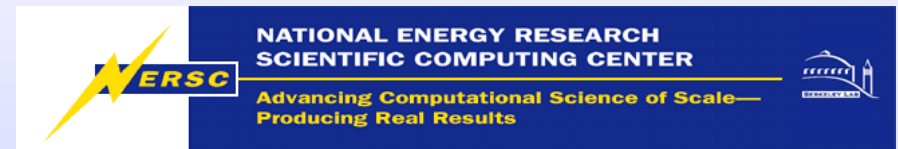
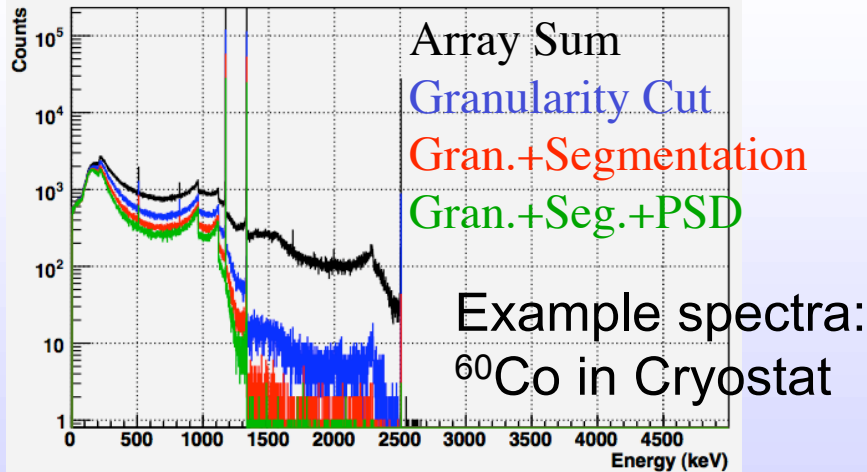



Majorana Sensitivity

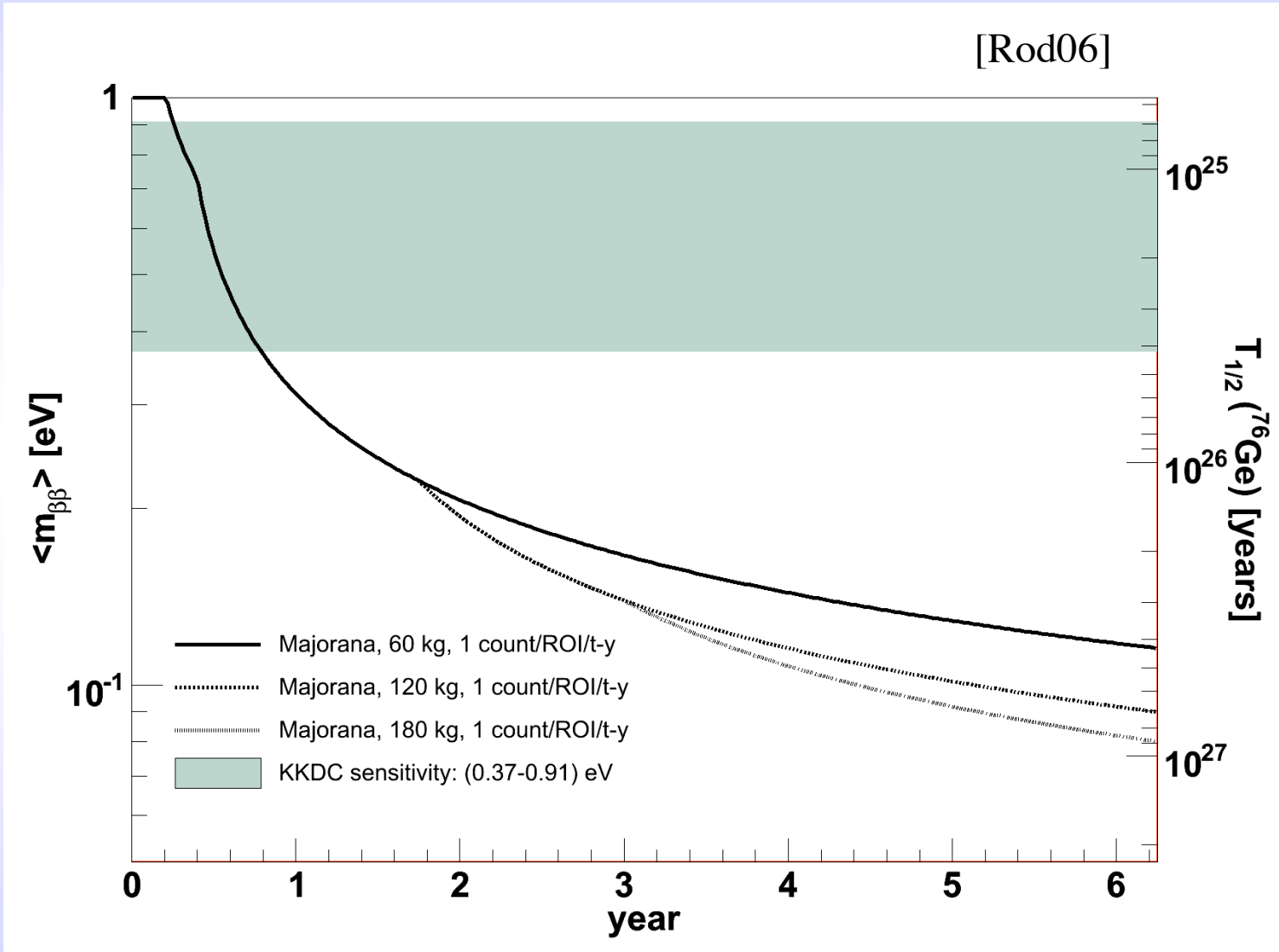



Schedule

- Submit R&D proposal this summer for prototype for 1-tonne.
- Construction in FY09.
- Collect data FY11. 30-60 kg. of enriched material.



Majorana Collaboration

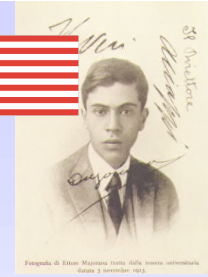

Institute for Theoretical and Experimental Physics, Moscow, Russia
Alexander Barabash, Sergey Konovalov,
Igor Vanushin, Vladimir Yumatov

Joint Institute for Nuclear Research, Dubna, Russia
Viktor Brudanin, Slava Egorov, **K. Gusev**, S. Katulina,
Oleg Kochetov, **M. Shirchenko**, Yu. Shitov, **V. Timkin**,
T. Vvlov, E. Yakushev, Yu. Yurkowski

Lawrence Berkeley National Laboratory, Berkeley, California
Yuen-Dat Chan, Mario Cromaz, Brian Fujikawa,
Donna Hurley, Kevin Lesko, Paul Luke, Akbar Mokhtarani,
Alan Poon, Gersende Prior, Nikolai Tolich, Craig Tull

Lawrence Livermore National Laboratory, Livermore, California
Dave Campbell, Kai Vetter

Los Alamos National Laboratory, Los Alamos, New Mexico
Steven Elliott, Gerry Garvey, **Victor M. Gehman**, Vincente
Guiseppe, Andrew Hime, Bill Louis, Geoffrey Mills, Kieth
Rielage, Larry Rodriguez, Richard Schirato, Laura Stonehill,
Richard Van de Water, Hywel White, Jan Wouters

Oak Ridge National Laboratory, Oak Ridge, Tennessee
Cyrus Baktash, Jim Beene, Fred Bertrand, Thomas V. Cianciolo, David
Radford, Krzysztof Rykaczewski, Chang-Hong Yu

Osaka University, Osaka, Japan
Hiroyasu Ejiri, Ryuta Hazama, Masaharu Nomachi, Shima Tatsuji

Note: Red text indicates students

4/16/07

Pacific Northwest National Laboratory, Richland, Washington
Craig Aalseth, Ronald Brodzinski, James Ely, Tom Farmer, Jim Fast,
Eric Hoppe, Brian Hyronimus, David Jordan, **Jeremy Kephart**, Richard
T. Kouzes, Harry Miley, John Orrell, Jim Reeves, Robert Runkle, Bob
Schenter, John Smart, Bob Thompson, Ray Warner, Glen Warren

Queen's University, Kingston, Ontario
Fraser Duncan, Aksel Hallin, Art McDonald

*Triangle Universities Nuclear Laboratory, Durham, North Carolina and
Physics Departments at Duke University and North Carolina State
University*
Henning Back, **James Esterline**, Reyco Henning, **Mary Kidd**, **Eliza
Osenbaugh-Stewart**, Werner Tornow, Albert Young

University of Chicago, Chicago, Illinois
Phil Barbeau, Juan Collar, Keith Crum, Smritri Mishra,
Brian Odom, Nathan Riley

University of South Carolina, Columbia, South Carolina
Frank Avignone, Richard Creswick, Horatio
A. Farach, **Todd Hossbach**, **George King**

University of South Dakota, Vermillion, South Dakota
Tina Keller, Dongming Mei

University of Tennessee, Knoxville, Tennessee
William Bugg, Tom Handler, Yuri Efremenko, Brandon White

University of Washington, Seattle, Washington
John Amsbaugh, Tom Burritt, Jason Detwiler, Peter J. Doe,
Alejandro Garcia, Mark Howe, **Rob Johnson**, **Michael Marino**,
Sean McGee, R. G. Hamish Robertson, **Alexis Schubert**,
Brent VanDevender, John F. Wilkerson

R. Henning -- UNC-CH

13